

An Alternative Refrigeration System For  
Automotive Applications

By

Shannon Marie McLaughlin

A Thesis  
Submitted to the Faculty of  
Mississippi State University  
in Partial Fulfillment of the Requirements  
for the Degree of Master of Science  
in Mechanical Engineering  
in the Department of Mechanical Engineering

Mississippi State, Mississippi

August 2005

# An Alternative Refrigeration System For Automotive Applications

By

Shannon Marie McLaughlin

Approved:

---

Dr. Pedro Mago  
Assistant Professor  
Mechanical Engineering  
(Major Professor)

---

Dr. Louay M. Chamra  
Associate Professor  
Mechanical Engineering  
(Committee Member)

---

Dr. B. Keith Hodge  
Professor  
Mechanical Engineering  
(Committee Member)

---

Dr. Steven R. Daniewicz  
Professor  
Mechanical Engineering  
(Graduate Coordinator)

---

Dr. Kirk H. Schulz  
Dean and Professor  
Bagley College of Engineering

Name: Shannon McLaughlin

Date of Degree: August 6, 2005

Institution: Mississippi State University

Major Field: Mechanical Engineering

Major Professor: Dr. Pedro Mago

Title of Study: AN ALTERNATIVE REFRIGERATION SYSTEM IN AUTOMOTIVE APPLICATIONS

Pages in Study: 46

Candidate for Degree of Master of Science

The air conditioning systems currently utilized in automobiles are the vapor compression systems. This type of system has many disadvantages: the refrigerant used is not environmentally friendly, the compressor is in competition with the engine coolant system, and the compressor uses a significant portion of the engine power. A waste heat driven absorption refrigeration system is one alternative to the current systems that could address these problems. The absorption refrigeration system uses solutions for the absorbent-refrigerant pair that do not harm the environment. This investigation includes a theoretical analysis of the feasibility of absorption air conditioning system in automotive applications. Also, a comparison of the power requirements of the proposed system and the vapor compression system is performed.

## ACKNOWLEDGMENTS

I would like to dedicate this research to my husband, Dino, and my children, Alyssa, Breanna, and Dino III. I would also like to thank my major professor, Dr. Pedro Mago, for his help throughout my time at Mississippi State and my advisory committee members, Dr. Louay Chamra and Dr. B. K. Hodge.

## TABLE OF CONTENTS

	Page
ACKNOWLEDGMENTS . . . . .	ii
LIST OF TABLES . . . . .	v
LIST OF FIGURES . . . . .	vi
NOMENCLATURE . . . . .	vii
CHAPTER	
I. INTRODUCTION . . . . .	1
1.1 Literature Review . . . . .	4
1.2 Absorption Refrigeration Cycle . . . . .	8
1.3 Working Fluid for Absorption Refrigeration Systems . . . . .	10
1.4 Alternate Refrigeration Systems . . . . .	13
II. MATHEMATICAL MODEL FOR ABSORPTION REFRIGERATION CYCLE . . . . .	16
2.1 Thermodynamic Analysis . . . . .	18
2.2 Properties for Working Fluid . . . . .	19
2.3 Waste Heat Available to Operate an Absorption Refrigeration System . . . . .	21
III. RESULTS AND DISCUSSION . . . . .	25
3.1 Comparison with Experimental Data . . . . .	25
3.2 Performance Analysis . . . . .	30
3.3 Corrosion Effects of LiBr-Water Solution . . . . .	36
3.4 Future Research . . . . .	37

IV. CONCLUSIONS AND RECOMMENDATIONS . . . . .	38
REFERENCES CITED . . . . .	40
APPENDIX . . . . .	45

## LIST OF TABLES

TABLE		PAGE
3.1	Thermodynamic analysis of vapor-compression automotive air-conditioning system presented by Boatto et al. (2000a) . . .	26
3.2	Thermodynamic analysis of absorption automotive air-conditioning system . . . . .	26
3.3	Vapor compression cycle condition of the experiments performed by Christy et al. (2001) . . . . .	28
3.4	Performance of the vapor compression system . . . . .	29
3.5	Performance of the absorption refrigeration system . . . . .	29

## LIST OF FIGURES

FIGURE		PAGE
1.1	Packard's 1939 refrigerated automobile air conditioning system (Hatcher, 1999) . . . . .	2
1.2	Absorption process . . . . .	9
1.3	Single-stage absorption refrigeration cycle . . . . .	10
1.4	Stirling schematic . . . . .	13
1.5	Orifice pulse-tube refrigerator (Radenbaugh 1990) . . . . .	15
2.1	Absorption refrigeration system with a solution heat exchanger . . .	17
2.2	Typical energy split in gasoline internal combustion engine . . . . .	22
2.3	Contour lines of fuel power in the rotational speed-engine power plane (Boatto et al. 2000a) . . . . .	22
3.1	Vapor compression cycle . . . . .	28
3.2	Change in heat transfer of each component as engine speed increases from idle, 1000 RPM, to cruise, 2000 RPM . . . . .	31
3.3	Rate of heat transfer for each component as a function of changing absorber temperature at 1000 RPM . . . . .	32
3.4	Rate of heat transfer for each component as a function of changing condenser temperature at 1000 RPM . . . . .	33
3.5	Rate of heat transfer for each component as a function of changing generator temperature at 1000 RPM . . . . .	34
3.6	Coefficient of performance as a function of changing absorber and generator temperatures . . . . .	35
3.7	Automotive single-effect absorption refrigeration system . . . . .	37



## NOMENCLATURE

$AF$	air-fuel ratio, $\text{kg}_{\text{air}}/\text{kg}_{\text{fuel}}$
$ARS$	absorption refrigeration system
$COP$	coefficient of performance
$FP$	fuel power, kW
$h$	enthalpy, kJ/kg
$\dot{m}$	mass flow rate, kg/s
$\dot{m}_{ref}$	mass flow rate of the refrigerant in the ARS, kg/s
$\dot{m}_{weak}$	mass flow rate of the weak LiBr-water solution in the ARS, kg/s
$\dot{m}_{strong}$	mass flow rate of the strong LiBr-water solution in the ARS, kg/s
$\dot{Q}$	rate of heat transfer in the evaporator, kW
$R$	air gas constant, 0.287 kJ/kg K
$T$	temperature, °C or K.
$\dot{V}$	induced volume, $\text{m}^3/\text{s}$
$VCS$	vapor compression system
$W$	specific work, kJ/kg
$\dot{W}$	power, kW
$x_{weak}$	mass fraction of the weak solution, ( $\text{kg}_{\text{LiBr}}/\text{kg}_{\text{solution}}$ )

$x_{strong}$  mass fraction of the strong solution, ( $\text{kg}_{\text{LiBr}}/\text{kg}_{\text{solution}}$ )

## **Subscripts**

<i>abs</i>	absorber
<i>comp</i>	compressor
<i>evap</i>	evaporator
<i>f</i>	fuel
<i>gen</i>	generator
<i>pump</i>	pump
<i>rejected</i>	rejected
<i>shx</i>	solution heat exchanger

# CHAPTER 1

## INTRODUCTION

Refrigeration systems can be defined as systems which remove heat at low temperatures and reject it at a higher temperature. The first refrigerated automobile air conditioning system, shown in Figure 1.1, was introduced by Packard in 1939 (Hatcher 1999). The vapor compression refrigeration system utilizes a refrigerant compressor that is shaft or belt driven by the automobile engine. In the past 65 years, automobile air conditioning systems have undergone gradual and continual improvements in performance and efficiency as a result of improvements in the individual components, compressor efficiency and size/weight reduction, control (thermostatic expansion valves, electronic compressor clutch cycling, and variable displacement compressor), and size/weight reduction of evaporators and condensers. Despite these component advances, the core technology has not changed, and there are still problems in the state of the art system that are continually being addressed.

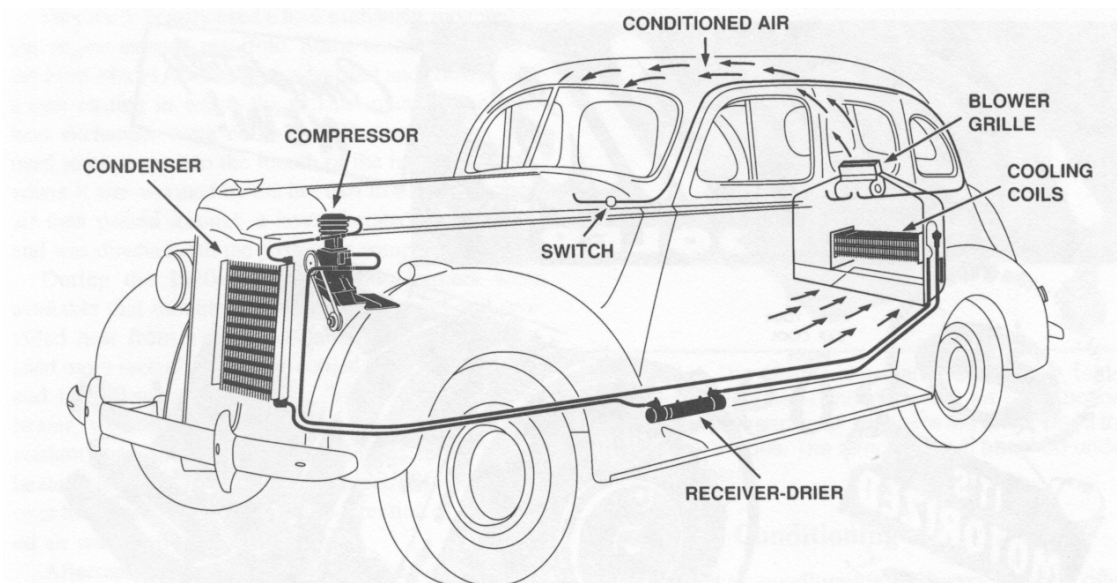

Figure 1.1 Packard's 1939 refrigerated automobile air conditioning system (Hatcher 1999)

The most pressing issue for the automotive air conditioning industry throughout the last decade and continuing today is the search for environmentally-friendly refrigerants. As a result of the Montreal Protocol of 1987 (an agreement among 23 countries including the United States to limit production of ozone-depleting chemicals) the industry searched extensively for a non-CFC refrigerant with the performance characteristics of R-12. This search resulted in the acceptance of R-134a, which has recently been identified by the Kyoto Protocol of 1997 as a “greenhouse” or global warming gas. Recently tests has been performed using two natural refrigerants, carbon dioxide ( $\text{CO}_2$ ) and butane/propane hydrocarbon (HC) refrigerant. Butane /propane hydrocarbon has similar refrigeration characteristics as R-134a, but can be explosive and

will require a secondary coolant loop to keep the explosive refrigerant away from the passenger compartment. Carbon dioxide is neither toxic nor explosive, but requires system pressures 7 to 10 times higher than R-134a. Both will cost more than R-134a, and neither will run as efficiently, which could cause increased emissions. Consequently, much of the work to reduce the global warming impact of automobile refrigerants has shifted to increasing the efficiency and reducing leakage in R-134a systems.

In addition to the concerns over the environmental impacts of automobile refrigerants, several mechanical issues are associated with powering the refrigerant compressor with the automobile engine. The power required to drive the compressor is often a significant portion of the total engine power output during city driving conditions. Also, the compressor must deliver the required amount of refrigerant to match the cooling load regardless of engine speed, which varies from 500 to 6000 rpm. Although variable displacement compressors are available for high-end vehicles, the most common means of controlling refrigerant flow is cycling the compressor. At compressor engagement, accelerating the rotational mass of the compressor and the mass of refrigerant in the system can double the engine torque, resulting in annoying engine surge and even stalling of smaller engines at idle. Furthermore, during engagement, the clutch must dissipate a large amount of heat; therefore, care must be taken to limit the clutch cycling. Another problem is the constant competition between the air conditioning system and the engine cooling system. The air conditioning condenser is located ahead of the engine cooling radiator restricting airflow to the radiator and preheating the air entering the radiator, placing an additional burden on the engine cooling system. By locating the condenser

behind the radiator a higher condenser pressure would result in decreased cooling capacity, increased compressor power, increased propensity of engine stalling, and premature failure of the compressor clutch or compressor.

Absorption-cycle refrigeration technology has the potential to eliminate the above concerns associated with conventional automotive air-conditioning technology. The absorption refrigeration cycle uses environmentally-friendly refrigerants and can be driven by waste heat from the vehicle engine rather than by siphoning valuable power from the engine. The objective of this investigation is to study the performance and feasibility of using a waste heat driven absorption refrigeration system as an alternative to the conventional vapor compression system that has been used by the automobile industry for years. To achieve this objective, a mathematical model will be developed to simulate the performance of the absorption refrigeration system and to compare the energy requirements of the absorption system to a vapor compression system.

## **1.1 Literature Review**

Many researchers have performed investigation on absorption refrigeration cycles. Some of them are: Tanaka and Gotoh (1998), Groll (1997), Tozer and James (1993), Joudi and Lafta (2000), Kumar and Devota (1990), Medrano et al. (2001), Levy et al. (2001), Kumar et al. (1991), and Kang et al. (2000). A current and comprehensive review of absorption refrigeration technologies and working fluids is contained in Srihirin et al., (2001). While literature dealing with absorption systems is abundant, studies dealing with the use of these types of systems in automobile applications are

relatively few. Among the investigators who have examined automobile absorption refrigeration systems are Boatto et al. (2000a, b), Riffat et al. (1994), and Horuz (1998 and 1999).

Boatto et al. (2000a) conducted extensive measurements on the exhaust system of a 2.0-liter, four-cylinder, spark-ignition engine of the type typically mounted in mid-sized passenger cars. The purpose of these tests was to characterize the amount of thermal power available to drive an absorption-cycle automotive cooling system from the exhaust gas stream throughout the normal range of engine operating conditions. A value for the available exhaust power in steady state conditions was determined. The results were subsequently used in the design and evaluation of several variations of an automotive absorption cooling system (Boatto et al., 2000b) to be used in a typical mid-sized passenger car in which this engine would be mounted. Based on theoretical analysis of their proposed prototype and experimental results from the typical mid-sized passenger car engine, Boatto et al. (2000b) conclude that an automotive absorption refrigeration system driven by exhaust heat recovery allows for considerable power recovery and seems feasible as long as provisions are made to store liquid refrigerant (water) for use during transient startups and when temporary exhaust gas power deficits occur.

Riffat et al. (1994) proposed an automobile air-conditioning system using a rotary absorption/recompression system using water/lithium bromide as the refrigerant absorbent pair. The proposed system utilizes a compressor and a rotating disc assembly mounted to a common shaft driven by the automobile engine. The rotating disc assembly functions as the generator, absorber and evaporator and is claimed to dramatically

increase the heat and mass transfer compared to conventional absorption equipment. Heat input to the generator is obtained from the condenser and the automobile engine exhaust. Riffat et al. (1994) predicted that the compressor power input to the proposed rotary absorption/recompression system is roughly the same as conventional automobile vapor-compression systems. Therefore, the only advantage over a conventional vapor-compression system would be that it uses “environmentally-benign” water as the refrigerant rather than HFC refrigerants. They determined the coefficient of performance, COP, of their system was between 3.97 and 5.63 based on generator temperatures and quality.

Horuz (1998, 1999) cites several theoretical applications on utilizing the main-engine exhaust gas for absorption-cycle refrigeration of cargo transport vehicles, but his study was unique in that it was the first to experimentally verify and report on the feasibility of such a system. While Horuz (1998, 1999) demonstrated that a vapor absorption refrigeration system running on a diesel engine is indeed possible, he also conceded that in order for such a system to be made feasible a number of issues remain to be addressed: the design of an exhaust-gas-heat-recovery exchanger/generator that imposes the same back pressure on the engine as the normal exhaust system, the effects of corrosive gases in the exhaust stream, the fluctuations in cooling capacity with variation in vehicle engine speed and load, and a means of alternative energy input while the cargo container is stationary.

The studies by Boatto et al. (2000a, b) and Horuz (1998, 1999) utilizes waste heat from the vehicle engine exhaust gas as the sole driving mechanism for their proposed



absorption refrigeration systems, and the study by Riffat et al. (1994) utilizes engine exhaust gas heat as a supplemental mechanism for powering the system. Both Boatto et al. (2000a, b) and Horuz (1998, 1999) conclude that engine exhaust gas heat would provide sufficient power to drive their proposed systems during normal cruise conditions (engine speeds around 2000 rpm) but would not provide sufficient capacity at rest (idle) or at slow-moving traffic conditions. Boatto et al. (2000a) points out that the high operating temperature required by the catalytic converter of spark-ignition engines imposes a limit on the amount of exhaust gas heat that can be recovered. Horuz (1998, 1999) points out the limitations imposed by exhaust gas back pressure on the engine and the effects of corrosive exhaust gases that could condense within exhaust system components as a result of extracting heat from the exhaust gases. Given the hurdles of using exhaust gas heat as the absorption-cycle driving mechanism, the feasibility of using heat from the engine cooling system instead of the exhaust gas to drive the absorption cycle is explored in this investigation.

Once the feasibility of an automobile absorption refrigeration system has been established, the absorption refrigeration system itself needs to be completely understood. Although literature dealing with absorption refrigeration systems is extensive, this review uses the information presented by Tanaka and Gotoh (1998), Tozer and James (1993), Joude and Lafta (2000), and Kumar et al. (1990). Tanaka and Gotoh (1998) reports characteristics of reliability and maintenance of the absorption refrigeration system. Their conclusions state that improvements of the reliability of individual units are required to improve the reliability of the absorption refrigeration system. Tozer and

James (1993) determined the thermodynamic basis to enable full understanding of the potential and limitations of absorption refrigeration cycles. They developed formulas defining temperature and COP relations for ideal absorption refrigeration cycles for a range of different applications and combinations. Joude and Lafta (2000) developed a steady-state computer simulation model to predict the performance of an absorption refrigeration system using lithium bromide-water, LiBr-water, as the working pair. Their simulation was successful and valid, giving qualitative and quantitative results for this type of refrigeration system. Similarly, Kumar et al. (1990) analyzed the performance of a closed-cycle absorption refrigeration system for simultaneous cooling and heating using LiBr-water. They found that the absorption system had an increase in coefficient of performance, COP, and the application was attractive from primary energy point of view. Their results showed that incorporating an auxiliary heat exchanger enabled the unit to provide effective simultaneous heating and cooling.

While there is a reasonable amount of interest in using waste heat for cooling and heating applications, there are areas that can benefit from additional research. Developing a mathematical model to simulate the performance of absorption refrigeration systems in automobile applications should, therefore, prove to be beneficial to the study.

## **1.2 Absorption Refrigeration Cycle**

The working fluid in an absorption refrigeration system is a binary solution consisting of refrigerant and an absorbent. In Figure 1.2 (a), the reservoir on the left contains refrigerant in liquid form while the reservoir on the right contains a solution of

the refrigerant and an absorbent. The solution in the right will absorb refrigerant vapor from the left reservoir causing a reduced vapor pressure. The temperature of the remaining refrigerant in the left reservoir will decrease as a result of vaporization causing a refrigeration effect to occur. At the same time, the solution inside the right reservoir becomes diluted because of the refrigerant absorbed. Normally, the absorption process is an exothermic process; therefore, rejecting heat out to the surrounding in order to maintain its absorption capabilities.

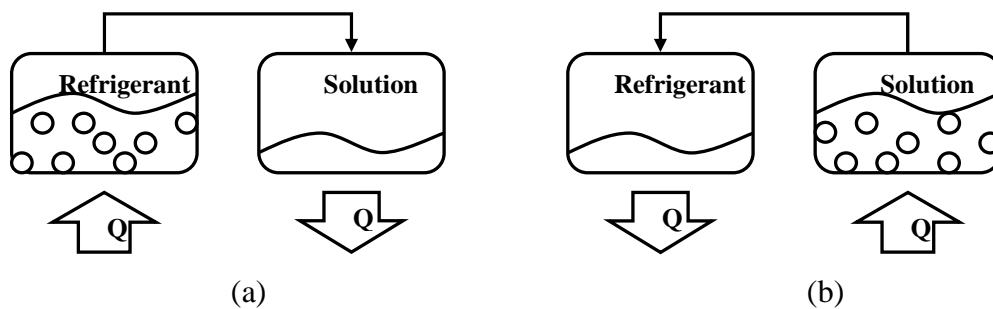

Figure 1.2 Absorption process

When the solution becomes saturated with the refrigerant and cannot absorb any more refrigerant, the refrigerant must be separated from the diluted solution. Heat is the key for the separation process. The heat is applied to the right reservoir in order to drive the refrigerant from the solution as shown in Figure 1.2 (b). By transferring heat to the surroundings, the refrigerant vapor will be condensed. With these processes, a refrigerant effect can be produced by using thermal energy. Since the two processes cannot be done simultaneously, the cooling effect cannot be produced continuously. An absorption

refrigeration cycle is a combination of these two processes as shown in Figure 1.3. A pump is required to circulate the solution, because the separation process occurs at a higher pressure than the absorption process.

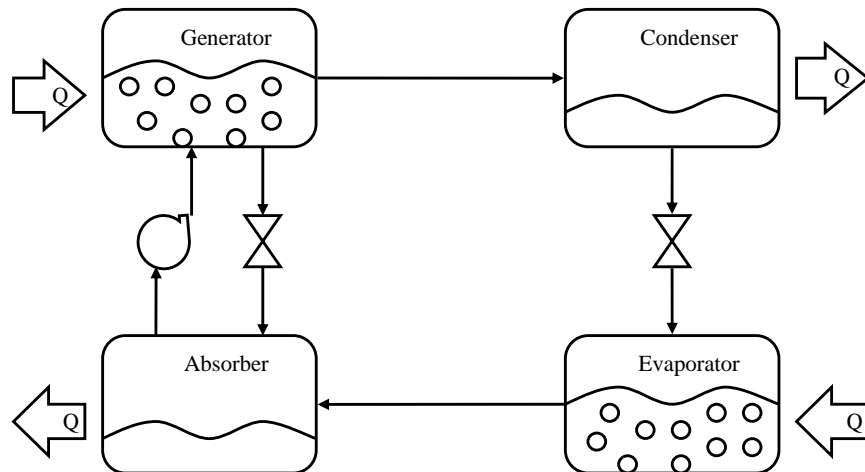

Figure 1.3 Single-stage absorption refrigeration cycle

### 1.3 Working Fluid for Absorption Refrigeration Systems

The performance of an absorption refrigeration system is vitally dependent on the chemical and thermodynamic properties of the working fluids used. A fundamental requirement of the absorbent/refrigerant combination is that, in liquid phase, they must have a margin of miscibility within the operating temperature range of the cycle. The mixture should also be chemically stable, non-toxic, and non-explosive. There is no ideal working pair suitable for every application because several of the requirements of a pair are contradictory. A summary of the requirements for working fluids is as follows:

### Refrigerant

- high specific enthalpy of evaporation
- favorable pressure range
- low pressure difference

### Refrigerant and absorbent

- high thermal and chemical stability
- good solubility of refrigerant in the absorbent
- low specific mass flowrate
- low heat of mixing
- low specific heat capacities
- large difference in boiling temperatures

The most important criteria for a working pair are thermal and chemical stability and good solubility of the refrigerant in the absorbent. The molecular basis for good solubility and thermal stability can be found with fluoridized alcohols (Nowaczyk and Steimle, 1992).

Over the years, many working fluids have been studied. Over 40 refrigerant compounds and 200 absorbent compounds are available (Srikhirin et al., 2001). The absorption process has been known for more than a century, but except for ammonia ( $\text{NH}_3$ )-water and water-lithium bromide (LiBr), other working pairs are rarely used.

Water- $\text{NH}_3$  has been widely used for both cooling and heating purposes since the absorption refrigeration system was invented. Both  $\text{NH}_3$ , the refrigerant, and water, the absorbent, are highly stable for a wide range of operating temperatures and pressures. Since ammonia and water are volatile, the cycle must include a rectifier to strip away water that normally evaporates with  $\text{NH}_3$  (Srikhirin et al, 2001). Without the rectifier, the water would accumulate in the evaporator and degrade system performance. The

disadvantages to water-NH<sub>3</sub> such are its high pressure, toxicity, and corrosive action to copper and copper alloys. However, water-NH<sub>3</sub> is environmentally friendly and cheap.

The use of LiBr-water for absorption refrigeration systems began around 1930. Two outstanding features of this pair are the non-volatility of LiBr and the extremely high heat of vaporization of water. However, using water as a refrigerant limits the low temperature application to that above 0°C. Since water is the refrigerant, the system must be operated under vacuum conditions. At high concentrations, the solution is prone to crystallization. It is corrosive to some metals, and is expensive. Some additive may be added to the pair as a corrosive inhibitor or to improve heat-mass transfer performance (Srikhirin et al, 2001).

Many studies have been performed on the applicability of the Freon refrigerants, R21 and R22, for refrigeration purposes using as the absorbents dimethyl formamide (DMF) and tetraethylene glycol dimethyl ether (DMETEG). A comparison of their working performances was also studied (Kumar et al, 1991). These studies are important for refrigeration of foodstuffs, vegetables, and fruits in tropical regions using low generator temperatures. These absorbents paired with Freon refrigerants are not especially useful for the automobile industry.

Water-NH<sub>3</sub> mixtures have been quiet extensively investigated. However, for smaller capacity applications, like automobiles, ammonia has the obvious drawbacks that it is toxic and that small leaks will cause an unacceptable odor. In contrast to this, carbon dioxide, CO<sub>2</sub>-acetone has the following advantages:

- harmless
- greatly reduced compression ratio compared to conventional refrigerants
- compatibility with common machine building materials and oils
- available
- simple operation and service
- no “recycling” required
- low cost

The only disadvantage is the high operating pressure of pure CO<sub>2</sub> (Groll, 1997).

### 1.4 Alternate Refrigeration Systems

The Stirling cycle and the pulse-tube unit were the alternate systems studied.

Among the many refrigeration cycles, the Stirling cycle, found in Figure 1.4, is selected as one of the promising candidates because of its use of non-CFC’s, simplicity, and high thermal efficiency. The Stirling cycle cooler is a free-piston, linear-motor driven device. The internal running surfaces are supported by gas bearings, so no contact wear takes place. The entire unit is sealed and it is capable of continuous modulation and of maintaining high efficiencies down to low loads, which means that it adapts easily to cooling needs and keeps performing with high efficiency even at low demand, (Kim et al., 1993).

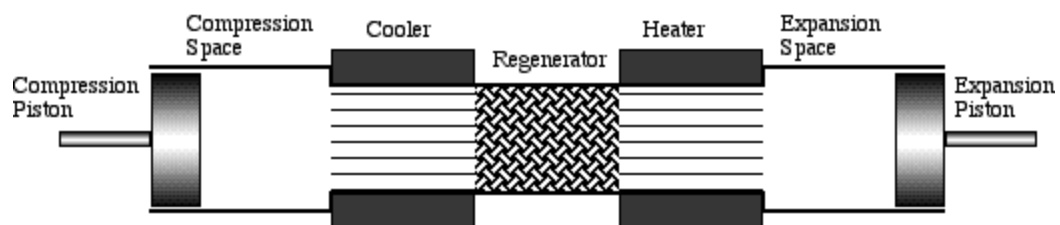

Figure 1.4 Stirling schematic

Stirling cycle refrigerators are not yet available on a commercial basis. They may well represent the future direction towards a super efficient, solar powered refrigerator. There are several characteristics that make Stirling engines impractical for use in many applications, including automotive. Because the heat source is external, some time is required for the engine to respond to changes in the amount of heat being applied to the cylinder because of the time required for the heat to be conducted through the cylinder walls and into the gas inside the engine. This means that

- The engine requires some time to warm up before it can produce useful power.
- The engine can not change its power output quickly.

These shortcomings all but guarantee, that the Stirling engine won't replace the internal-combustion engine for automotive use.

The pulse-tube refrigeration unit offers a viable alternative to systems that currently require chlorofluorocarbon (CFC) or hydro-chlorofluorocarbon (HCFC) working fluids. The pulse-tube refrigeration unit uses helium, which is nontoxic to humans and harmless to the environment, as the working fluid. Pulse-tube refrigerators can be operated over a wide range of temperatures. With only a single moving part, the pulse-tube refrigerator offers the potential for greater reliability than the Stirling cooler (Radenbaugh, 1990). These systems can be used in numerous space and commercial refrigeration applications, including food refrigerator/freezers, laboratory freezers, and freeze dryers. Pulse-tube refrigerators can also be used to cool detectors and electronic devices.



Pulse-tube refrigeration, a variation of the Stirling engine, is new compared to other refrigeration cycles. The pulse-tube refrigerator was first developed in mid-1960 by Gifford and Longworth (Radenbaugh, 1990).

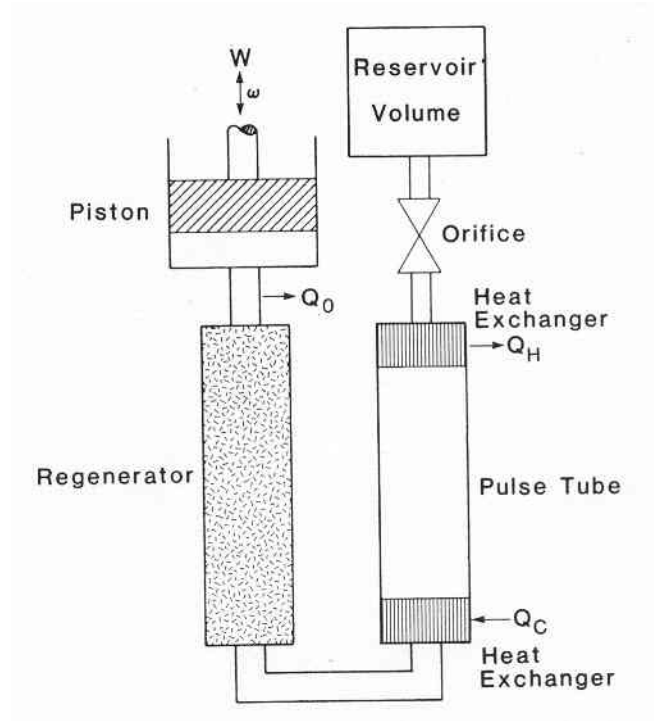

Figure 1.5 Orifice pulse-tube refrigerator (Ranenbaugh, 1990)

Pulse-tube refrigerators offer increased reliability and fewer moving parts. However, one disadvantage of pulse tube coolers is the difficulty in scaling them down to sizes as small as 0.15 W at 80K while maintaining high efficiency. This disadvantage has limited their use in many practical applications.

## CHAPTER 2

### MATHEMATICAL MODEL FOR ABSORPTION REFRIGERATION CYCLE

This chapter presents the mathematical model developed to study the feasibility and performance of the absorption refrigeration system as an alternative to the conventional vapor compression system for automotive applications. The use of the waste heat from the engine coolant system is explored. Some arguments in favor of using the engine coolant heat are as follows. A rule-of-thumb for typical heat engines is that for every unit of fuel power input, roughly one-third is converted to useful power, roughly one-third is rejected through the engine cooling system, and the remaining one-third is rejected through the exhaust system. Recovering waste heat from the engine coolant rather than the exhaust gases eliminates all concerns associated with engine back pressure, catalytic converter operation, and corrosive exhaust gases.

Although a number of advanced absorption cycle technologies are available, the best choice for the proposed automobile absorption system is the single-effect absorption cycle. Figure 2.1 shows a schematic of the absorption refrigeration cycle used to develop the thermodynamic relations. Only pure refrigerant is assumed to flow through the condenser, expansion valve, and evaporator. The refrigerant vapor leaving the evaporator

is absorbed into a liquid solution in the absorber to make a strong solution. The pressure of the strong liquid solution is increased by a pump, and the solution is preheated in the heat exchanger. The addition of heat in the generator drives out refrigerant vapor out of the strong liquid solution into the condenser. The weak solution returns to the absorber through the solution heat exchanger and an expansion valve. In the proposed absorption refrigeration system, waste heat from the motor coolant system will be used in the generator to separate the refrigerant vapor from the strong liquid solution.

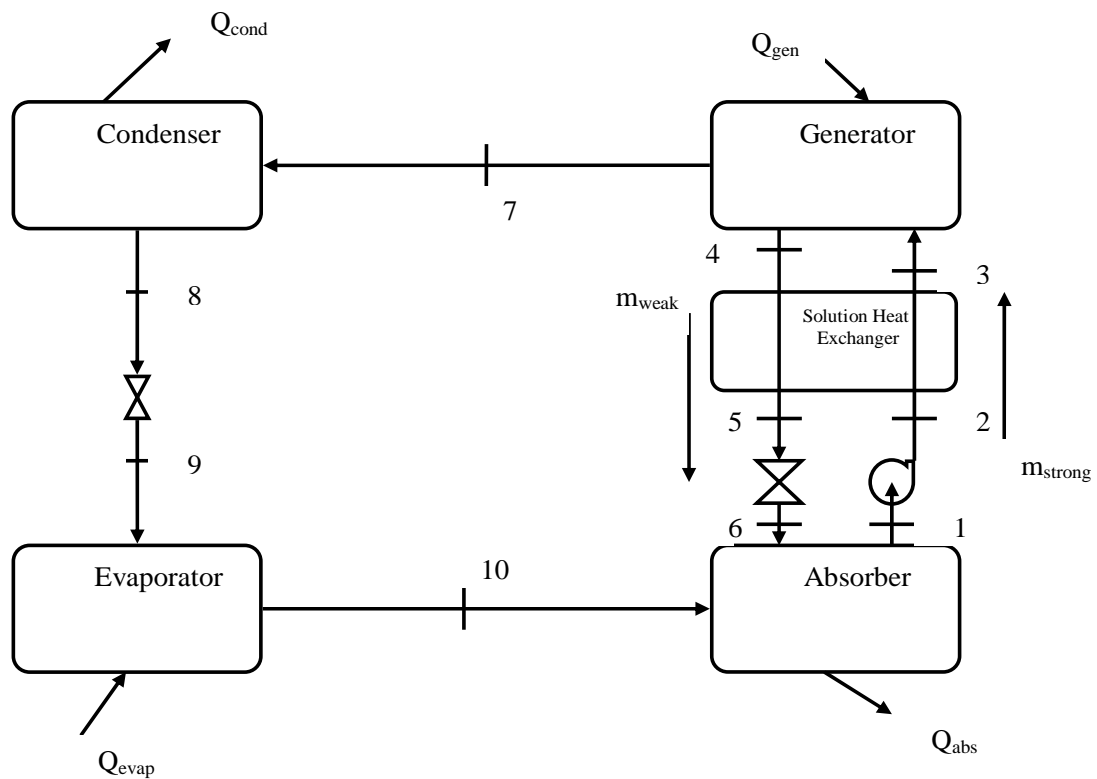

Figure 2.1 Absorption refrigeration system with a solution heat exchanger

## 2.1 Thermodynamic Analysis

To perform a thermodynamic analysis for an absorption refrigeration system, the conservation of mass and the first law of thermodynamics were applied to individual components of the system. Mass conservation includes the mass balance of the total mass and the mass balance of each material species.

The governing equations of each component of the absorption system depicted in Figure 2.1 can be expressed as follows:

For the absorber:

$$\dot{m}_{strong} = \dot{m}_{ref} + \dot{m}_{weak} \quad (2.1)$$

$$\dot{m}_{weak} x_{weak} = \dot{m}_{strong} x_{strong} \quad (2.2)$$

$$\dot{Q}_{abs} = \dot{m}_{strong} h_1 - \dot{m}_{weak} h_6 - \dot{m}_{ref} h_{10} \quad (2.3)$$

where

$$\dot{m}_{strong} = \dot{m}_3 = \dot{m}_2 = \dot{m}_1 \quad = \text{mass flow rate of the strong solution,}$$

$$\dot{m}_{ref} = \dot{m}_{10} = \dot{m}_9 = \dot{m}_8 = \dot{m}_7 \quad = \text{mass flow rate of refrigerant}$$

$$\dot{m}_{weak} = \dot{m}_4 = \dot{m}_5 = \dot{m}_6 \quad = \text{mass flow rate of the weak solution}$$

For the evaporator:

$$\dot{Q}_{evap} = \dot{m}_{ref} (h_{10} - h_9) \quad (2.4)$$

For the condenser:

$$\dot{Q}_{cond} = \dot{m}_{ref} (h_8 - h_7) \quad (2.5)$$

For the expansion valves:

$$h_8 = h_9 \quad (2.6)$$

$$h_5 = h_6 \quad (2.7)$$

For the generator:

$$\dot{Q}_{gen} = \dot{m}_{ref} h_7 + \dot{m}_{weak} h_4 - \dot{m}_{strong} h_3 \quad (2.8)$$

For the pump:

$$W_{pump} = \dot{m}_{strong} (h_1 - h_2) \quad (2.9)$$

For the solution heat exchanger:

$$\dot{m}_{strong} (h_2 - h_3) = \dot{m}_{weak} (h_5 - h_4) \quad (2.10)$$

The coefficient of performance, which is a ratio of the energy received by the system to the net work transfer of energy into the system, can be expressed as

$$COP = \frac{\dot{Q}_{evap}}{\dot{Q}_{gen}} \quad (2.11)$$

## 2.2 Properties for Working Fluid

Equations (2.1) through (2.11) are valid for any working fluid pair. However, this investigation uses lithium bromide, LiBr,-water mixture as the absorbent refrigerant pair of the absorption cycle. LiBr-water was chosen because of its inherent simplicity, availability, and extensive documentation of the working fluid properties. The properties of the LiBr were determined using a computer program called Interactive Thermodynamics version 2.0 (Moran et al. 2000). The equations used to determine the

properties are shown in Appendix A. The solutions obtained from this software were compared with those obtained using the relations presented by McNeely (1979), and the values for the change in enthalpy agree well.

McNeely (1979) presented the equilibrium equations of enthalpy, temperature, and concentration of the LiBr-water solution. The relationship of temperatures, concentration, and pressure are given by [modified to SI units]

$$T = A(T_{ref} + 17.778) + 0.556B - 17.778 \quad (2.12)$$

$$P = 6.8994 \exp \left[ 6.21147 - \frac{2886.373}{(1.8T_{ref} + 492.67)} - \frac{33726.46}{(1.8T_{ref} + 492.67)^2} \right] \quad (2.13)$$

where

$T$  = solution temperature (°C)

$T_{ref}$  = refrigerant temperature (°C)

$P$  = pressure (kPa)

$A$  and  $B$  = constants define in Equations (2.14) and (2.15)

$X$  = concentration (% LiBr).

$$A = -2.00755 + 0.16976X - 3.13336 \times 10^{-3} X^2 + 1.97668 \times 10^{-5} X^3 \quad (2.14)$$

$$B = 321.128 - 19.322X + 3.74382 \times 10^{-1} X^2 - 2.0637 \times 10^{-3} X^3 \quad (2.15)$$

Equations (2.12) and (2.13) are valid for solution temperatures between 4.5°C and 177°C, refrigerant temperatures between -17.8°C and 110°C, and concentrations between 45% and 70%.

The enthalpy of the LiBr/water solution can be determined as follows:

$$h = C + D(1.8T + 32) + E(1.8T + 32)^2 \quad (2.16)$$

where

$C$ ,  $D$ , and  $E$  = constants defined in Equations (2.17), (2.18), and (2.19)

$$C = -1015.07 + 79.5387X - 2.358016X^2 + 0.0303158X^3 - 1.40026 \times 10^{-4}X^4 \quad (2.17)$$

$$D = 4.6811 - 0.30378X + 8.4485 \times 10^{-3}X^2 - 1.0477 \times 10^{-4}X^3 + 4.80 \times 10^{-7}X^4 \quad (2.18)$$

$$E = -4.9 \times 10^{-3} + 3.83 \times 10^{-4}X - 1.08 \times 10^{-5}X^2 + 1.315 \times 10^{-7}X^3 - 5.9 \times 10^{-10}X^4 \quad (2.19)$$

### **2.3 Waste Heat Available to Operate an Absorption Refrigeration System**

The available heat rejected by the cooling system can be estimated if the fuel power of the engine is known. The fuel power parameter is a function of the calorific value of the fuel and it is distributed as 30% engine power, 30% coolant, and 40% exhaust gas, as shown in Figure 2.2. These values were verified with the experiments performed by Boatto et al. (2000a). The experiments, Boatto et al. (2000a) show that as the motor speed (RPM) increases at constant engine power, the fuel power and exhaust power increases. In a similar manner, for the same RPM, an increase in the engine power results in an increase in the fuel power and exhaust gas power.

From Figure 2.3 at 1300 RPM the engine power is 10 kW, while the fuel power and exhaust gas power are 30 kW and 5 kW, respectively. Because fuel power is equal to engine power, coolant power, and exhaust power, the energy available from coolant for cooling is 15 kW. Similarly, at 2000 RPM, the engine power is about 24 kW, while the

fuel power and exhaust gas power are about 70 kW and 17 kW, respectively. Therefore, the energy for cooling is about 29 kW.

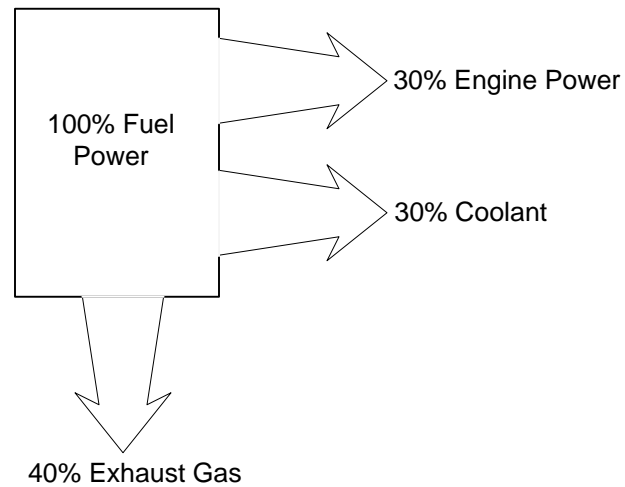

Figure 2.2 Typical energy split in gasoline internal combustion engine

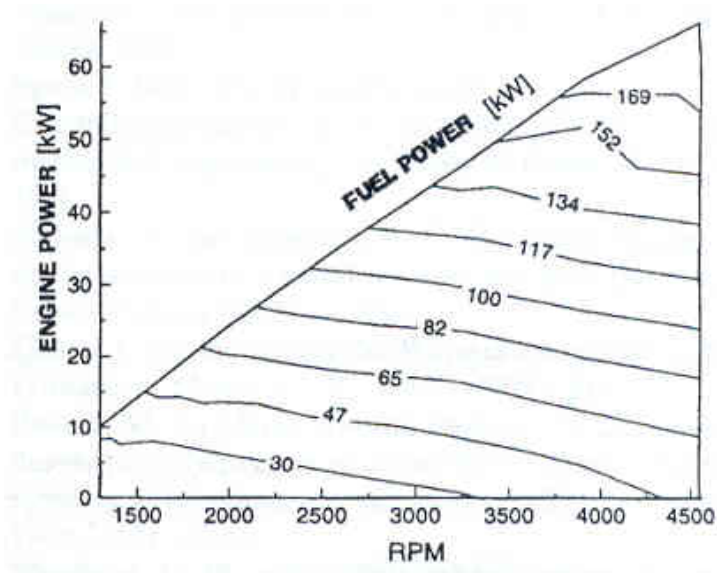

Figure 2.3 Contour lines of fuel power in the rotational speed-engine power plane (Boatto et al. 2000a)



For both cases, the energy used for the coolant is around 45%, which is even more than the 30% shown in Figure 2.2. To take a more conservative approach, the assumption for this model will be made that the available heat rejected from the coolant system is approximately 30%. From the results presented by Boatto et al. (2000a) for a typical four-cylinder car engine at idle (1000 RPM), the available heat is approximately 11 kW; at cruise (2000 RPM) the available heat is about 29 kW.

The fuel power can be determined by (Pulkrabek, 2004):

$$FP = \dot{m}_f CV \quad (2.20)$$

where

$\dot{m}_f$  = fuel mass flow rate

$CV$  = calorific value of the fuel.

The available heat rejected by the cooling system can be expressed as:

$$Q_{rejected} = 0.3 \dot{m}_f CV \quad (2.21)$$

The heat rejected is used in the generator of the absorption refrigeration system;

therefore, Equation (2.7) can be written as

$$Q_{gen} = 0.3 \dot{m}_f CV = \dot{m}_{ref} h_7 + \dot{m}_{weak} h_4 - \dot{m}_{strong} h_3 \quad (2.22)$$

The COP of the absorption refrigeration system can be written in terms of the fuel mass flow rate and calorific value as

$$COP = \frac{\dot{m}_{ref} (h_{10} - h_9)}{0.3 \dot{m}_f CV} \quad (2.23)$$

The mass flow rate of the fuel can be determined using the air-fuel ratio:

$$AF = \frac{\dot{m}_a}{\dot{m}_f} \quad (2.24)$$

where

$\dot{m}_a$  = mass of the air, which can be determine using the ideal gas equation

## CHAPTER 3

### RESULTS AND DISCUSSION

#### **3.1 Comparison with Experimental Data**

The feasibility of an automotive absorption refrigeration system was evaluated using experimental results reported by Boatto et al. (2000a) and Christy et al. (2001). Conventional automotive air-conditioning systems are typically designed to meet the maximum cooling load while operating at typical driving conditions (approximately 2000 rpm) and are expected to meet steady-state cooling loads while operating at idle conditions (approximately 1000 rpm). The results of a thermodynamic analysis of a typical R-134a vapor-compression system mounted in a mid-sized car, such as the one presented in Boatto et al. (2000a, 2000b), are shown in Table 3.1. These analysis shows that a typical vapor compression system installed in their experimental passenger car would be capable of providing more than the design steady-state 2 kW cooling load at both idle and cruise conditions.

Table 3.1 Thermodynamic analysis of vapor-compression automotive air-conditioning system presented by Boatto et al. (2000a)

$P_{cond}$ (kPa)	$P_{evap}$ (kPa)	$T_{cond}$ (°C)	$T_{evap}$ (°C)	RPM	$m_{ref}$ (kg/sec)	Disp. (m <sup>3</sup> /rev)	$W_{comp}$ (kW)	$Q_{cond}$ (kW)	$Q_{evap}$ (kW)	$\eta_{isen}$	$\eta_{vol}$	COP
1574	314	57	0	1000	0.027	$1.37 \times 10^{-4}$	1.1	4.21	3.1	0.85	0.815	2.8
1574	314	57	0	2000	0.054	$1.37 \times 10^{-4}$	2.2	8.42	6.21	0.85	0.815	2.8

Table 3.2 states the results of a thermodynamic analysis of the proposed absorption system on a design cooling capacity of 7.03 kW (the required transient startup cooling load rounded up to two tons). At this design condition, the required waste heat input to the generator is 10.7 kW. According to Boatto et al. (2000a), at normal driving conditions, the waste heat available from the exhaust gas would be marginally sufficient, but the waste heat available from the engine coolant is more than sufficient. At idle conditions and slow-moving traffic conditions, conditions which normally tend to overheat the engine cooling system, the cooling capacity will be ample to maintain steady-state conditions and the absorption cooling system will actually help the cooling system rather work than against it (as the conventional compressor driven systems do).

Table 3.2 Thermodynamic analysis of absorption automotive air-conditioning system

$P_{abs}$ (kPa)	$P_{cond}$ (kPa)	$P_{evap}$ (kPa)	$P_{gen}$ (kPa)	$T_{abs}$ (°C)	$T_{evap}$ (°C)	$T_{gen}$ (°C)	$\dot{m}_{ref}$ (kg/s)	$\dot{m}_{strong}$ (kg/s)	$\dot{m}_{weak}$ (kg/s)	$\dot{Q}_{evap}$ (kW)	$\dot{Q}_{cond}$ (kW)	$\dot{Q}_{gen}$ (kW)	$W_{pump}$ (W)	COP
1.02	13.41	1.02	13.41	37.8	7.2	93.3	0.003	0.078	0.075	7.03	7.52	10.65	2.98	0.7

The results of Table 3.1 and Table 3.2, reveals that an absorption refrigeration system with a cooling capacity of 7.03 kW, higher than that of a conventional vapor compression system (3.1 kW at idle and 6.21 kW at cruise) requires less power to operate. The absorption refrigeration system only requires 2.98 W to operate the pump, while the vapor compression system requires 1100 W at idle and 2200 W at cruise to operate the compressor.

Similarly, a comparison was performed with experimental data reported by Christy et al. (2001). Table 3.3 states the experimental temperatures and pressures for a vapor compression system, found in Figure 3.1, while Table 3.4 reports the results (COP, the cooling capacity, and the compressor power) reported by Christy et al. (2001). From Table 3.4, at idle conditions the cooling capacity is 3.85 kW while at cruise conditions the cooling capacity increases to 6.72 kW. The performance of an absorption refrigeration system that would provide the same cooling capacities (at idle and cruise conditions) as the vapor compression system described in Table 3.3 was evaluated and presented in Table 3.5.

Table 3.3 Vapor compression cycle condition of the experiments performed by Christy et al. (2001)

Experimental Conditions	Idle (1000 rpm)	Cruise (2000 rpm)
$T1$	16.7°C	3.9°C
$P1$	510.2 kPa	330.9 kPa
$T2$	16.7°C	3.9°C
$P2$	461.9 kPa	303.4 kPa
$T3$	93.9°C	90.6°C
$P3$	2227 kPa	1724 kPa
$T4$	70°C	50.6°C
$P4$	2117 kPa	1641 kPa
$T5$	19.4°C	6.7°C
$P5$	565.4 kPa	365.4 kPa
$\dot{m}_{ref}$	0.037 kg/s	0.052 kg/s

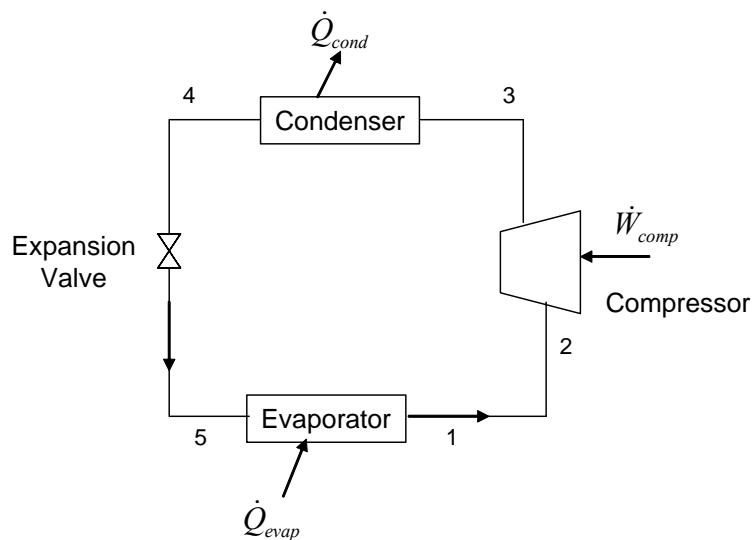

Figure 3.1 Vapor compression cycle

Table 3.4 Performance of the vapor compression system

Parameter	Idle (1000 rpm)	Cruise (2000 rpm)
$\dot{Q}_{evap}$	3.85 kW	6.72 kW
$\dot{W}_{comp}$	1.88 kW	3.23 kW
$COP$	2.04	2.07

Table 3.5 Performance of the absorption refrigeration system

	Idle (1000 rpm)	Cruise (2000 rpm)
$\dot{Q}_{evap}$	3.85 kW	6.72 kW
$\dot{Q}_{gen}$	8.45 kW	14.76 kW
$\dot{W}_{pump}$	0.0056 kW	0.0098 kW
$\dot{Q}_{abs}$	8.19 kW	14.30 kW
$\dot{Q}_{cond}$	4.11 kW	7.18 kW
$COP$	0.45	0.45

From the comparisons from Boatto et al. (2000a) and Christy et al (2001), where both systems provide the same amount of cooling, the absorption refrigeration cycle has a significantly decreased power requirement (approximately 99.7%) compared to the power required by the vapor compression system. The extra power that is not being used can be converted back to engine power. Although the COP for the absorption refrigeration cycle is less than that of the vapor compression cycle, the power savings more than make up for the decreased COP. Based on the two comparisons, an absorption refrigeration air conditioner driven by the waste heat of the vehicle engine's cooling system is indeed feasible.

### 3.2 Performance Analysis

Now that the feasibility of the absorption refrigeration system has been established, the influence of different parameters on the performance of the system was investigated. To accomplish the parametric study, a typical 3-liter capacity, 4-stroke carbureted engine was used. The operational conditions of the engine were as follows: air fuel ratio of 15; air supplied at 520 kPa and 15°C with a mechanical efficiency of 0.75, and the calorific value for gasoline is 46000 kJ/kg. The total fuel power was determined using Equations (2.20), (2.24), and (2.25). For idle conditions, the total fuel power was determined to be 36 kW; therefore, the heat available from the coolant for cooling was approximately 10.8 kW. For cruise conditions, the total fuel power was 90.4 kW; therefore, the heat available for cooling was approximately 27.1 kW. According with these results, the waste heat from the coolant system was between 10.8 kW and 27.1 kW from idle to cruise, respectively. Using this range, the effect of the available heat to be used in the generator was evaluated for different engine speeds. Figure 3.2 illustrates the evaporator, condenser, and absorber heat rates for a range of generator heat rates from 9 kW to 28 kW. The evaporator heat rate increases with the engine speed from 4.8 kW at 1000 RPM to a maximum of 13.1 kW at 2000 RPM. The condenser and absorber heat rates also increase with increasing engine speed. The worst case scenario (when the system has the smaller cooling capacity) is at idle when the available waste heat from the coolant system has the smaller value.



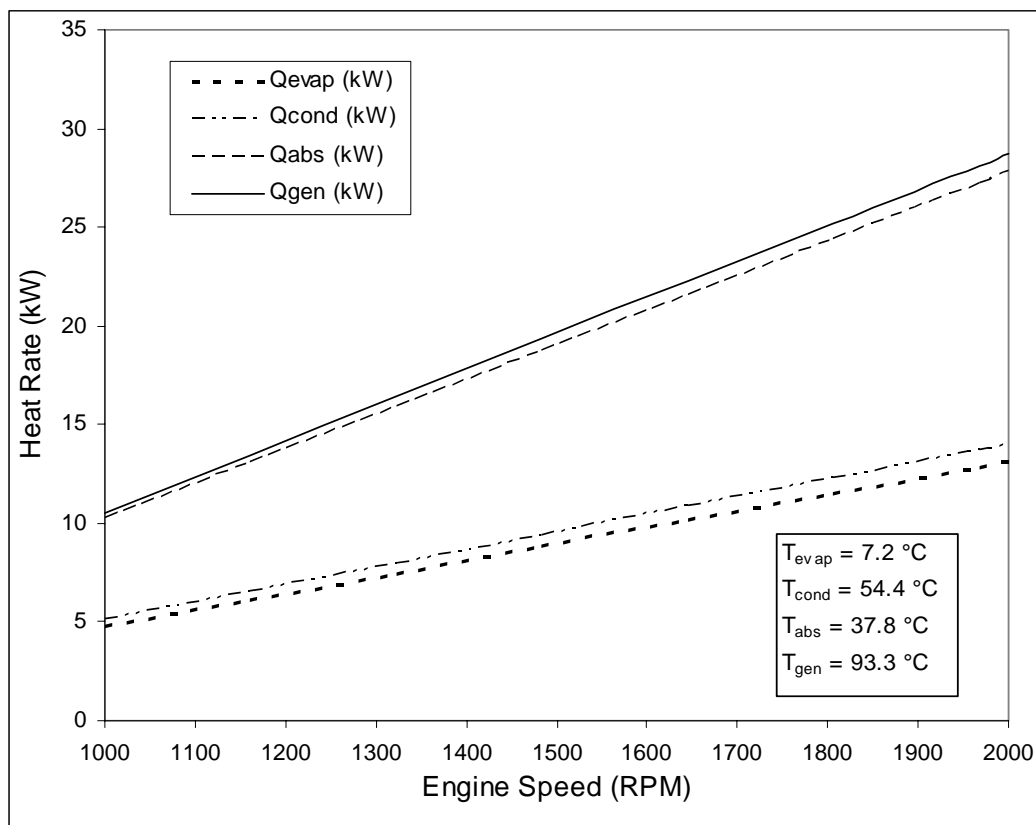

Figure 3.2 Change in heat transfer of each component as engine speed increases from idle, 1000 RPM, to cruise, 2000 RPM

An analysis was performed using the lowest heat available for the generator to find the limitations (or restrictions) of the proposed system at idle conditions. Figure 3.3 demonstrates the variation of the heat transfer rates of each component as the absorber temperature varies at idle conditions (generator heat rate was kept constant at 9 kW). This figure also illustrates that the evaporator and condenser heat rates decrease when the absorber temperature is increased. The absorber heat rate showed a slight increase when the absorber temperature is increased. The evaporator capacity decreases from 8.2 kW at 27°C to 2 kW at 39°C. As can be seen from the figure, temperatures higher than 39°C can

be a problem for the system performance since the cooling capacity drops significantly.

This can be a limitation of the applicability of the system in extremely hot locations.

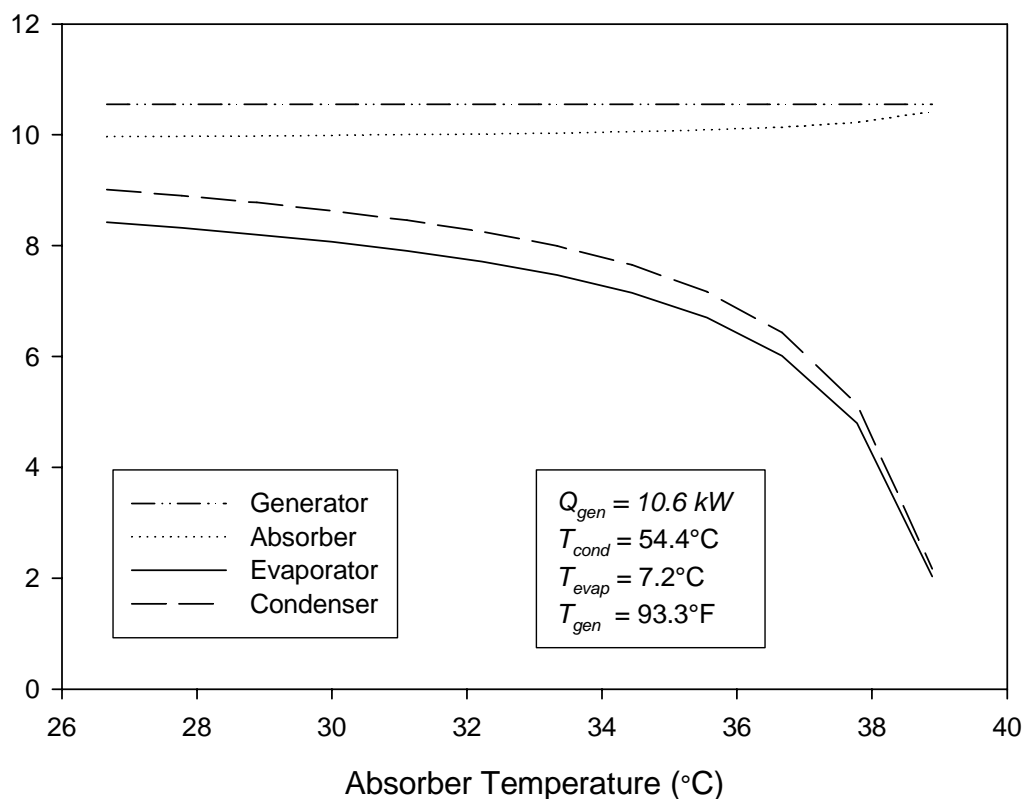

Figure 3.3 Rate of heat transfer for each component as a function of changing absorber temperature at 1000 RPM

Figure 3.4 explains the variation of the heat transfer rates of each component with increasing condenser temperature during idle conditions. The results presented in this figure are similar to those shown in Figure 3.3. The evaporator and condenser heat rate decreases, when the condenser temperature is increased, and the absorber heat rate slightly increases when the absorber temperature is increased. The evaporator capacity

decreases from 8.2 kW at 43.3°C to 2 kW at 55.5°C. These results indicate that the condenser temperature has to be kept lower than 55.5°C in order to have at least 2 kW of cooling capacity.

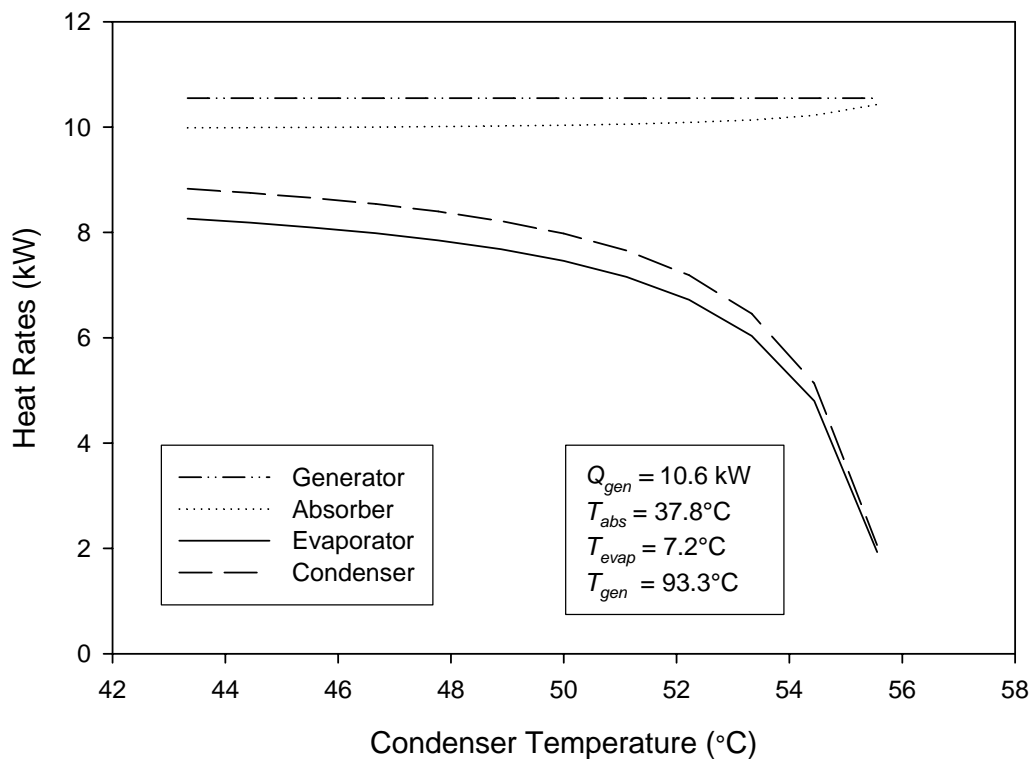

Figure 3.4 Rate of heat transfer for each component as a function of changing condenser temperature at 1000 RPM

Figure 3.5 illustrates the heat transfer rates of each component with the variation of the generator temperature during idle conditions. Figure 3.5 infers that the minimum generator temperature must be around 93°C to have more than 2 kW of cooling capacity in the evaporator. At this temperature, 93 °C, the motor must be running at 121°C which is very hot for an engine. That high a temperature becomes a problem because the engine

components can only withstand so much heat before they start to wear out prematurely.

The evaporator and condenser heat rates increase with an increase in the generator temperature, while the absorber heat rate slightly decreases. According to the results presented in Figure 3.5, the higher the generator temperature, the better the system will perform.

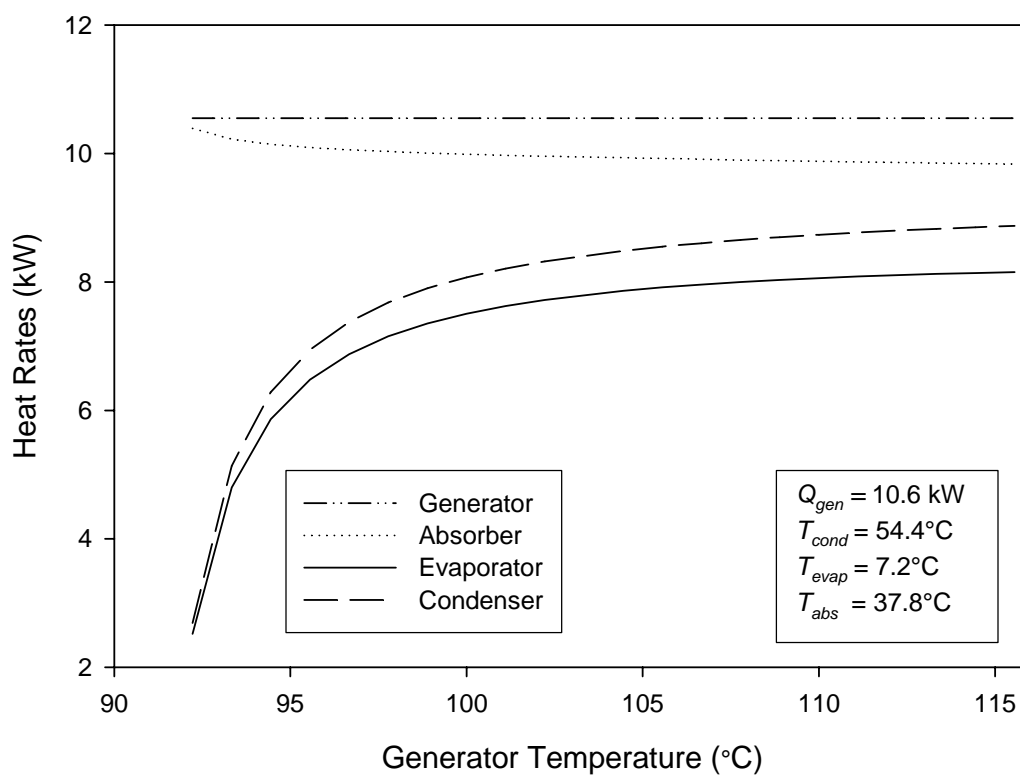

Figure 3.5 Rate of heat transfer for each component as a function of changing generator temperature at 1000 RPM

Figure 3.6 shows the variation of the coefficient of performance of the system for two different scenarios: (1) changing the absorber temperature while keeping the other conditions constant, (2) and varying the generator temperature while keeping the other conditions constant. This figure illustrates that for Scenario 1, the COP decreases when the absorber temperature increases while for Scenario 2, the COP increases when the generator temperature is increased. The last result agrees with the results presented in Figure 3.5, since an increase in the generator temperature will increase the evaporator cooling capacity.

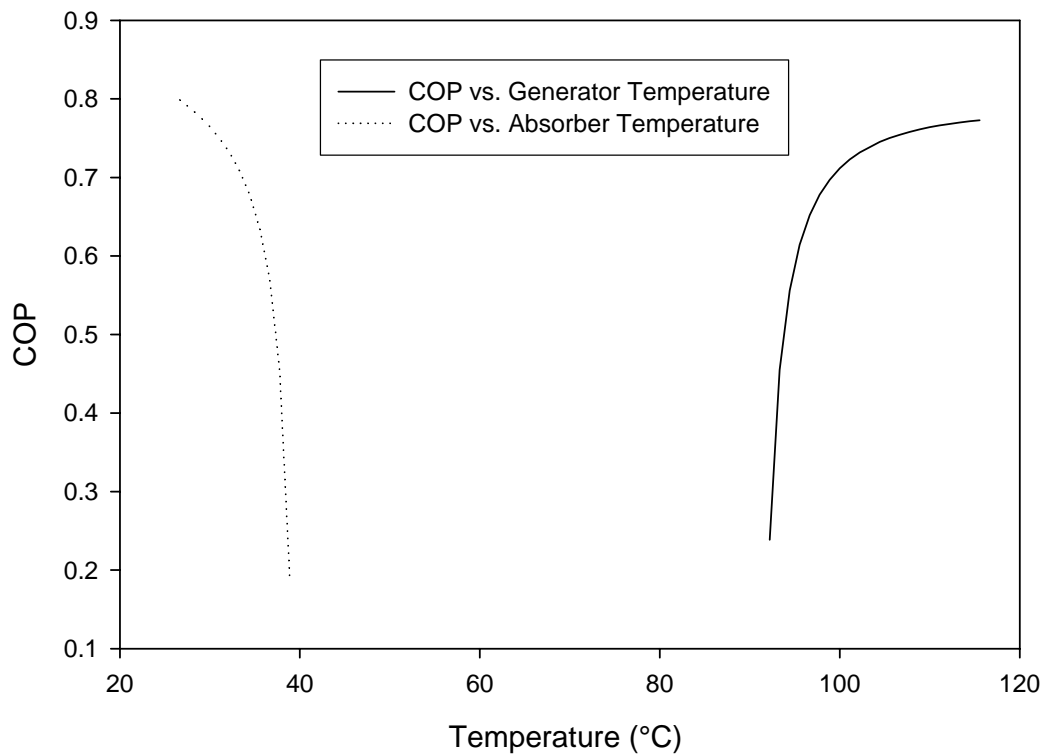

Figure 3.6 Coefficient of performance as a function of changing absorber and generator temperatures

### 3.3 Corrosion Effects of LiBr-Water Solution

One of the major concerns of using lithium bromide, LiBr,-water solutions in absorption refrigeration systems is the corrosion problem. Lithium bromide is a salt-based substance and causes corrosion especially when mixed with water. Different researchers have investigated the corrosive effects of lithium bromide solutions on different materials. Guinon et al. (1994) studied the effects of aqueous LiBr solution on carbon steels, stainless steels, and titanium. They investigated the effects of LiBr concentration, pH, temperature, exposure time, and the actions of some inhibitors on corrosion of these metals. Similarly, Iqual et al. (2002) performed a corrosion behavior and galvanic study of brass and bronzes in an aqueous lithium bromide solution. They found that a chromate and lithium hydroxide presence in commercial LiBr solution produced a complete inhibition on brass, but inhibitor was not suitable for bronze. Iqual et al. (2003) studied the effects of corrosion on copper-nickel alloy in an aqueous lithium bromide solution. This study concluded that under particular conditions of pH and concentration of LiBr solution, alloying with nickel improved corrosion resistance. Iqual et al. (2003) also reported that the inhibition effect of commercial LiBr was always higher for copper and lower for nickel. Tsyqankova et al. (1991) proved that hydroquinoline films could significantly reduce the corrosion rate of carbon steel in concentrated lithium bromide solution and could prevent the local surface damage.

### 3.4 Future Research

The proposed absorption refrigeration prototype air conditioning system is depicted in Figure 3.7. This is a preliminary investigation that will lead to future research in which such a system could be installed in an automobile and tests run in order to validate the temperatures and component limitations reported in this thesis.

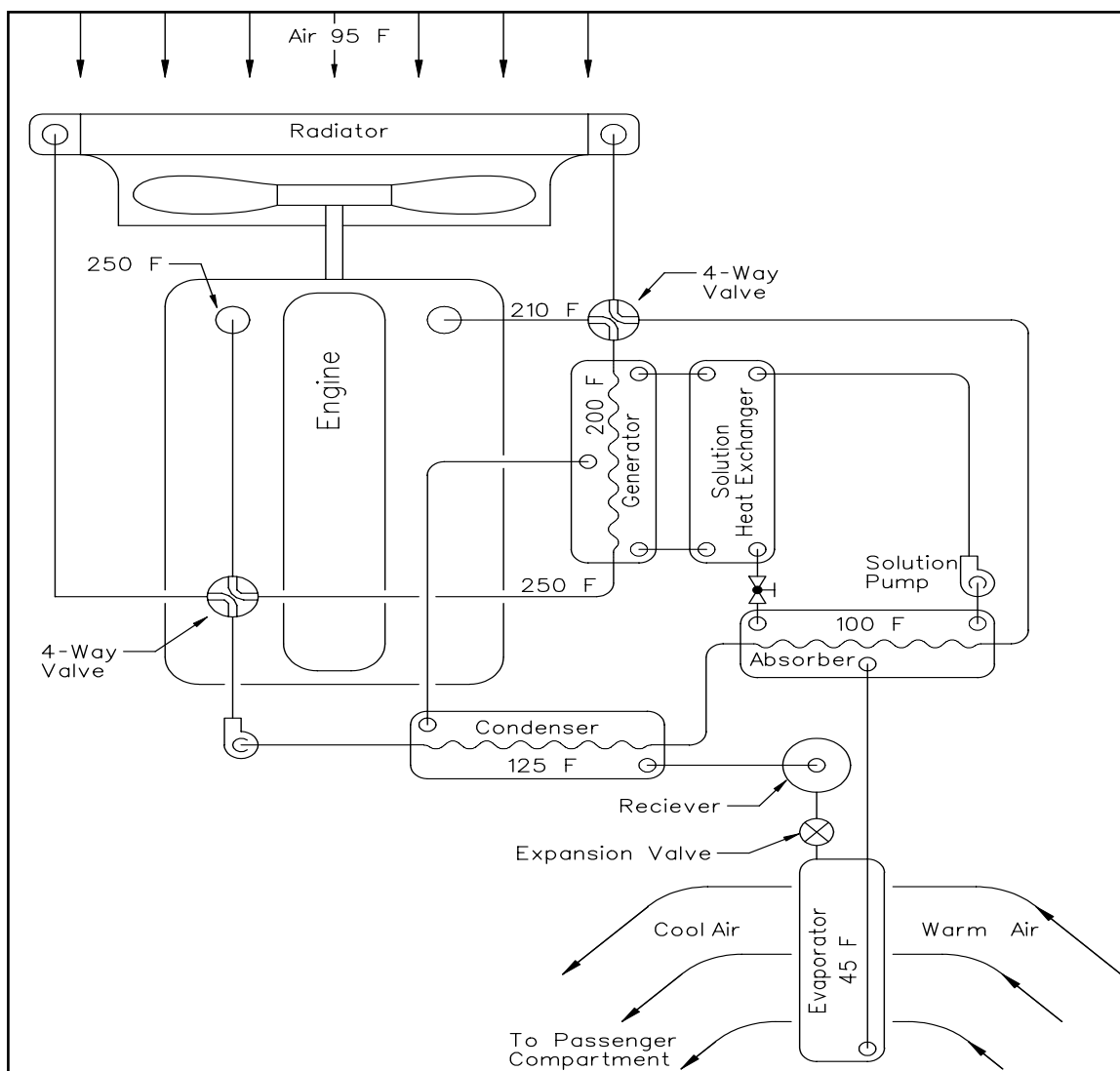

Figure 3.7 Automotive single-effect absorption refrigeration system

## CHAPTER 4

### CONCLUSIONS AND RECOMMENDATIONS

The absorption refrigeration system is a feasible alternative to the traditional vapor compression system for automotive case. The absorption refrigeration systems use an environmentally-refrigerants and very little power for operation when compared to traditional vapor compression systems. The reduction in power can be achieved because the system can be operated using the waste heat rejected from the engine coolant system and because no compressor is required.

In order for the system to run at the most favorable conditions, the outside air temperature needs to be below 38°C which can be a problem in places with extremely high temperatures. The minimum generator temperature should be around 93°C. Ideally, the system will work best if the motor is running at 115.5°C. Also the condenser temperature must be below 55.5°C. The absorption refrigeration system will work for temperatures out of the above mentioned ranges, but the efficiency drops off rather drastically.

A recommendation for future work includes construction of an absorption cycle prototype air conditioning system for installation in a fully functional automobile to demonstrate proof of concept. An automotive prototype would be more likely to spawn future funding for development and research. A research and development study would



include control optimization, component improvements (such as absorber and generator heat mass transfer enhancements), and the development/documentation of alternative refrigerant-absorbent pairs. Moreover, expediently proving the concept of a coolant waste heat driven cycle using a conventional internal combustion engine paves the way for absorption refrigeration air conditioning systems to become a standard for the contemporary vehicles. The system could be powered by a hydrogen-fueled internal combustion engine, a fuel cell, or a hybrid electric system – any power system that produces waste heat.

## REFERENCES CITED

- Boatto, P.; Boccaletti, C.; Cerri, G.; Malvicino, C., 2000, "Internal combustion engine waste heat potential for an automotive absorption system of air conditioning Part 1: tests on the exhaust system of a spark-ignition engine," *Proceedings of the Institute of Mechanical Engineers*, Vol. 214, No. 8, pp. 979-982.
- Boatto, P.; Boccaletti, C.; Cerri, G.; Malvicino, C., 2000, "Internal combustion engine waste heat potential for an automotive absorption system of air conditioning Part 2: the automotive absorption system," *Proceedings of the Institute of Mechanical Engineers*, Vol. 214, No. 8, pp. 983-989.
- Christy, C.; Fusco, D.; Toosi, R., 2001, "Adsorption Air-Conditioning for Containerships and Vehicles," *METRANS Final Report*, Contract Number 65A0047. June.
- Groll, Eckhard A., 1997, "Modeling of absorption/compression cycles using working pairs carbon dioxide/acetone," *Proceedings of the 1997 ASHRAE Winter Meeting*, Philadelphia, PA, USA, and published in *ASHRAE Transactions*, Vol. 103, No. 1, pp. 863-872.
- Guinon, J. L.; Garcia-Anton, J.; Perez-Herranz, V.; Lacoste, G., 1994, "Corrosion of carbon steels, stainless steels, and titanium in aqueous lithium bromide solution," *National Association of Corrosion Engineers*, Houston, TX, Vol. 50, No. 3, pp. 240-246.
- Hatcher, Lissy, 1999, *Automotive Heating, Ventilation, and Air-Conditioning Systems*, 2<sup>nd</sup> Edition, Check-Chart Publications, Sunnyvale, CA.
- Horuz, 1998, "Alternative road transport refrigeration," *Turkish Journal of Engineering & Environmental Sciences*, Vol. 22, No. 3, pp. 211-222.
- Horuz, I., 1999, "Vapor absorption refrigeration in road transport vehicles," *Journal of Energy Engineering*, Vol. 125, No. 2, pp. 48-58.
- Iqbal Munoz, A.; Garcia Anton, J.; Guinon, J. L.; Perez Herranz, V., 2002, "Corrosion behavior and galvanic studies of brass and bronzes in aqueous lithium bromide solutions," *National Association of Corrosion Engineers*, Vol. 58, No. 7, pp. 560-569.

- Igual Munoz, A.; Garcia Anton, J.; Guinon, J. L.; Perez Herranz, V., 2003, "Effect of aqueous lithium bromide solutions on the corrosion resistance and galvanic behavior of copper-nickel alloy," *National Association of Corrosion Engineers*, Vol. 59, No. 1, pp. 32-41.
- Joudi, K.A., Lafta, A.H., 2001, "Simulation of a simple absorption refrigeration system," *Energy Conversion and Management*, Vol. 42, No. 13, pp.1575-1605.
- Kang, Y. T.; Kunugi, Y.; Kashiwagi, T., 2000, "Review of advances absorption cycles: Performance improvement and temperature lift enhancement," *International Journal of Refrigeration*, Vol. 23, No. 5, pp. 388-401.
- Kim, Sung-Tae; Cho, Kwan-Shik; Chung, Woo-Suk, 1993, "Study of stirling cycle refrigerator," *Proceedings of the 28th Intersociety Energy Conversion Engineering Conference*, Atlanta, GA, USA, and published in *Proceedings of the Intersociety Energy Conversion Engineering Conference*, Vol. 2, pp. 615-619.
- Kumar, P.; Devotta, S., 1990, "Study of an absorption refrigeration system for simultaneous cooling and heating," *1990 Annual Meeting of the American Society of Heating, Refrigerating and Air-Conditioning Engineers, Technical and Symposium Papers*, Atlanta, GA, USA, and published in *ASHRAE Transactions*, Vol. 96, No. 2, pp. 291-298.
- Kumar, S.; Prevost, M.; Bugarel, R., 1991, "Comparison of various working pairs for absorption refrigeration systems. Application of R21 and R22 as refrigerants," *Revue Internationale Du Froid*, Vol. 14, No. 5, pp. 304-310.
- Levy, A.; Jelinek, M.; Borde, I., 2001, "Single stage absorption system based on refrigerants R125 and R134a with DMETEG," *Strojniški Vestnik*, Vol. 47, No. 8, pp. 497-500.
- McNeely, L.A., 1979, "Thermodynamics Properties of Aqueous Solution of Lithium Bromide," *ASHRAE Transactions*, Vol. 85, No. 1, pp. 413-434.
- Medrano, M.; Bourouis, M.; Coronas, A., 2001, "Double-lift absorption refrigeration cycles driven by low-temperature heat sources using organic fluid mixtures as working pairs," *Applied Energy*, Vol. 68, No. 2, pp. 173-185.
- Moran, Michael; Shapiro, Howard, 2000, *Fundamentals of Engineering Thermodynamics*, 4<sup>th</sup> Edition, John Wiley & Sons, Inc., New York.
- Pulkrabek, Willard, 2004, *Engineering Fundamentals of the Internal Combustion Engine*, 2<sup>nd</sup> Edition, Pearson Prentice Hall, Upper Saddle River, New Jersey.

- Radenbaugh, Ray, 1990, "Review of pulse tube refrigeration," *Proceedings of the 1989 Cryogenic Engineering Conference*, Los Angeles, CA, USA, and published in *Advances in Cryogenic Engineering*, Vol. 35, Pt. B, pp. 1191-1205.
- Riffat, S.B.; Wong, C.W.; Shankland, N., 1994, "Automobile air-conditioning using a rotary absorption/recompression system," *Applied Energy*, Vol. 49, No. 1, pp. 9-16.
- Srikhirin, P., Aphornratana, S., Chungpaibulpatana, S., 2001, "A review of absorption refrigeration technologies," *Renewable & Sustainable Energy Reviews*, Vol. 5, No. 4, pp. 343-372.
- Tanaka, Hisashi; Kitada, Motohiro; Taniguchi, Yousuke; Ohno, Yumi; Shinagawa, Tutomu; Aoki, Hiroshi, 1992, "Study on car air conditioning system controlled by car occupants' skin temperatures Part 2 development of a new air conditioning system," *International Congress and Exposition*, Detroit, MI, USA, and published in *SAE Technical Paper Series*, p. 21-27.
- Tanaka, T.; Gotoh, S., 1998, "Reliability analysis of absorption refrigerating system," *Proceedings of the 1998 Conference on Cryogenics and Refrigeration*, ICCR, Hangzhou, China, pp. 194-197.
- Tozer, Robert M.; James, Ron W., 1994, "Thermodynamics of absorption refrigeration: Ideal cycles," *Proceedings of the International Absorption Heat Pump Conference*, New Orleans, LA, USA, pp. 393-400.

### **Additional References**

- Air Conditioning and Refrigeration Institute, 1998, *Refrigeration and Air Conditioning*, Third Edition, Editor: Ed Francis, Prentice Hall, Upper Saddle River, New Jersey.
- Birch, Tom, 2003, *Automotive Heating and Air Conditioning*, Third Edition, Prentice Hall, Upper Saddle River, New Jersey.
- Boer, D.; Valles, M.; Coronas, A., 1998, "Performance of double effect absorption compression cycles for air-conditioning using methanol-TEGDME and TFE-TEGDME systems as working pairs," *Revue internationale du froid*, Vol. 21, No. 7, pp. 542-555.
- Borde, I.; Jelinek, M.; Daltrophe, N. C., 1997, "Working fluids for an absorption system based on R124 (2-chloro-1,1,1,2-tetrafluoroethane) and organic absorbents," *International Journal of Refrigeration*, Vol. 20, No. 4, pp. 256-266.

- Chen, Shuhui; Chen, Guangming; Zheng, Fei; Wang, Jianfeng; Zhong, Yongfang; Feng, Yangpu; Zhang, 2000, "Experimental study on R22 alternative working fluids in absorption refrigerating system," *Tai yang neng xue bao = Acta energiae solaris sinica*, Vol. 21, No. 1, pp. 89-94.
- Fatouh, M.; Srinivasa Murthy, S., 1993, "Comparison of R22-absorbent pairs for absorption cooling based on P-T-X data," *Renewable energy*, Vol. 3, No. 1, pp. 31-37.
- Ingersoll, John G.; Kalman, Thomas G.; Maxwell, Linda M.; Niemiec, Robert J., 1992, "Automobile passenger compartment thermal comfort model Part I Compartment cooldawn/warm -up calculations," *International Congress and Exposition*, Detroit, MI, USA, and published in *SAE Technical Paper Series*, pp. 1-11.
- Ingersoll, John G.; Kalman, Thomas G.; Maxwell, Linda M.; Niemiec, Robert J., 1992, "Automobile passenger compartment thermal comfort model Part II Human thermal comfort calculation," *International Congress and Exposition*, Detroit, MI, USA, and published in *SAE Technical Paper Series*, pp. 1-11.
- Kouremenos, D.A.; Rogdakis, E.D., 1995, "Efficiency of a propane/n-hexadecane absorption refrigeration cycle," *Proceedings of the 1995 ASME International Mechanical Engineering Congress and Exposition*, San Francisco, CA, USA, and published in *American Society of Mechanical Engineers, Advanced Energy Systems Division (Publication) AES*, pp. 305-310.
- Liang, J.; Ravex, A.; Rolland, P., 1996, "Study on pulse tube refrigeration Part 1 thermodynamic nonsymmetry effect," *Cryogenics*, Vol. 36, No. 2, pp. 87-93.
- Liang, J.; Ravex, A.; Rolland, P., 1996, "Study on pulse tube refrigeration Part 2 theoretical modeling," *Cryogenics*, Vol. 36, No. 2, pp. 95-99.
- Liang, J.; Ravex, A.; Rolland, P., 1996, "Study on pulse tube refrigeration Part 3 experimental verification," *Cryogenics*, Vol. 36, No. 2, pp. 101-106.
- Lin, C.H.; Han, T.; Koromilas, C.A., 1992, "Effects of HVAC design parameters on passenger thermal comfort," *International Congress and Exposition*, Detroit, MI, USA, and published in *SAE Technical Paper Series*, pp. 1-23.
- Nowaczyk, U.; Steimle, F., 1992, "Thermophysical properties of new working fluid systems for absorption processes," *Revue Internationale Du Froid*, Vol. 15, No. 1, pp. 10-15.
- Riffat, S.B.; Wong, C.W., 1994, "Gas-driven absorption/recompression system," *Heat recovery systems & CHP*, Vol. 14, No. 2, pp. 165-171.

Ruiter, J.P., 1990, "Simplified thermodynamic description of mixtures and solutions," *Revue Internationale Du Froid*, Vol. 13, No. 4, pp. 223-236.

Tsygankova, L. E.; Vigdorovich, V. I.; Budenevich, A. P.; Semerikova, I. A.; Baranenko, A. V.; Volkova, O. V., 1991, "Protection of steel by hydroxyquinoline films from sorrosion in lithium bromide solutions," Vol. 27, No. 2, pp. 288-291.

Taniguchi, Yousuke; Aoki, Hiroshi; Fujikake, Kenji; Tanaka, Hisashi; Kitada, Motohiro, "Study on car air conditioning system controlled by car occupants' skin temperatures Part 1 research on a method of quantitative evaluation of car occupants' thermal sensstions by skin temperatures," *International Congress and Exposition*, Detroit, MI, USA, and published in *SAE Technical Paper Series*, pp. 13-19.

## APPENDIX A

This is the set of equations input into the computer program in order to find the enthalpies, and rate of heat transfers (Moran et al., 2000).

```
//LiBr-Water Refrigeration Cycle
Tgen=200 //°F Weak solution leaving, superheated vapor leaving
Tevap=45 //°F Saturated water vapor leaving
Tabs=100 //°F Strong solution leaving
Tcond=130 //°F Saturated liquid water leaving
Qevap=13116 //Btu/hr
Qgen=12000 //Btu/hr
eff_shx=0.7

Pevap = Psat_T("Water/Steam", Tevap) //lbf/in2
Pabs = Pevap //lbf/in2
Pcond= Psat_T("Water/Steam", Tcond) //lbf/in2
Pgen = Pcond //lbf/in2

T1=Tabs //°F
T2=T1 //°F
T4=Tgen //°F
T3=T2+eff_shx*(T4-T2) //°F
T7=Tgen //°F
T8=Tcond //°F
T9=Tevap //°F
T10=Tevap //°F

Tevap = Tr_LiBr_TX(Tabs,Xs) //°F finds Xs implicitly
Tcond = Tr_LiBr_TX(Tgen,Xw) //°F finds Xw implicitly

h1=h_LiBr_TX(T1,Xs) //Btu/lb
rho1=62.4*(0.017*Xs+0.7) //Btu/lb
h2 = h1+(Pgen-Pabs)/rho1 //Btu/lb
h3 = h_LiBr_TX(T3,Xs) //Btu/lb
h4 = h_LiBr_TX(T4,Xw) //Btu/lb
h5=h4-(mstrong/mweak)*(h3-h2) //Btu/lb
h6=h5 //Btu/lb
h7=h_PT("Water/Steam", Pgen, T7) //Btu/lb
h8=hsat_Px("Water/Steam", Pcond, 0) //Btu/lb
h9=h8 //Btu/lb
h10=hsat_Px("Water/Steam", Pevap, 1) //Btu/lb

mref=Qevap/(h10-h9) //lb/hr
mstrong=mref/(1-Xs/Xw) //lb/hr
mweak=mstrong*(Xs/Xw) //lb/hr

Qcond=mref*(h7-h8) //Btu/hr
Qabs=mref*h10+mweak*h6-mstrong*h1 //Btu/hr
Qshx=mstrong*(h3-h2) //Btu/hr
Wp=mstrong*(h2-h1) //Btu/hr
PHP=Wp/3412/0.75 //horsepower

COP=Qevap/Qgen
```